



reventon

Technical documentation

Energy Recovery Unit INSPIRO BASIC

MODELS:

INSPIRO BASIC 200
INSPIRO BASIC 300
INSPIRO BASIC 400
INSPIRO BASIC 600
INSPIRO BASIC 800
INSPIRO BASIC 1000
INSPIRO BASIC 1300



EN

- 1. INTRODUCTION
 - 1.1 PRECAUTIONS
 - 1.2 TRANSPORT
 - 1.3 PACKAGE CONTENT
 - 1.4 USE
- 2. DEVICE CHARACTERISTIC
 - 2.1 CONSTRUCTION AND PRINCIPLE OF OPERATION
 - 2.2 DEVICE DIMENSIONS
 - 2.3 DEVICE TECHNICAL DATA
 - 2.4 WORKING CHARACTERISTICS
- 3. ASSEMBLY
 - 3.1 GENERAL PRINCIPLES
 - 3.2 DUCTING
- 4. INSTALLATION INSTRUCTIONS
 - 4.1 CONNECTION OF THE DEVICE TO THE ELECTRICAL SYSTEM
- 5. PRECAUTIONS & WARNINGS
- 6. CONTROLS
 - 6.1 CHARACTERISTIC
 - 6.2 COMMISSIONING
 - 6.3 CONTROL PANEL BASIC
- 7. CONNECTIONS SCHEMES
- 8. TERMS OF WARRANTY

1. INTRODUCTION

Thank you very much for purchasing energy recovery unit INSPIRO BASIC. We would like to congratulate you on excellent choice. Please read and keep this manual.

1.1 PRECAUTIONS

The buyer and the user of the device Reventon Group brand should read carefully the following instructions and proceed to the content recommendations. Proceeding due to the following instruction guarantees the correct usage and safety. In case of any doubts please contact directly Reventon Group sp. z o. o. [Ltd.]. The supplier reserves the rights to make changes to the technical documentation without previous notice. Reventon Group sp. z o. o. [Ltd.] is not responsible for the damages which occur due to improper installation, not keeping the device in repair or using the device out of line. The installation should be carried out by the professional installers, who possess the qualifications to install these types of devices. The installers are responsible for making the installation as instructed in the technical data. In case of unserviceable please plug out the device and contact with the authorized repair person or the supplier. During the installation, use, service and periodical inspections all regulations and safety rules must be followed.

1.2 TRANSPORT

During the acceptance of goods, it is needed to check the device to exclude any damages. During the transport, it is needed to use the proper equipment, it is necessary to carry the device by two people. In case of any damages please fill in the damage report in presence of the supplier.

1.3 PACKAGE CONTENT

- energy recovery unit
- instruction and warranty card
- control panel STANDARD

1.4 USE

Energy recovery units Reventon Group INSPIRO BASIC series are designed for ventilation systems as an important element enabling energy recovery (heat and moisture). These devices enable ventilation of the building. They are designed for ventilation of residential buildings as well as halls, warehouses, shops, services or workshops. Energy recovery allows for a significant reduction of the building's operating costs.

2. DEVICE CHARACTERISTICS

2.1 CONSTRUCTION AND PRINCIPLE OF OPERATION

Casing: made of steel. It has handles for easy assembly of the device. The connectors are made of plastic and have diameters enables of installation of the most popular sizes of ventilation ducts. The housing has an inspection door that allows for easy access to filters and exchanger.

Enthalpy heat exchanger: made of the special material enabling efficient recovery of heat and moisture from room exhaust air. Thanks to the recovery of moisture in many cases there is no need for using additional humidifier.

Filters: the unit has two prefilters G3 (on the supply and exhaust), which properly maintained (see point 5) guarantee appropriate purity of the air supplied to the rooms.

Supply and exhaust fan: 3-stage AC fans which ensure airflow through the exchanger and ventilation ducts. Detailed performance characteristics of the whole units can be found in section 2.4.

2.2 DEVICE DIMENSIONS

INSPIRO BASIC 200

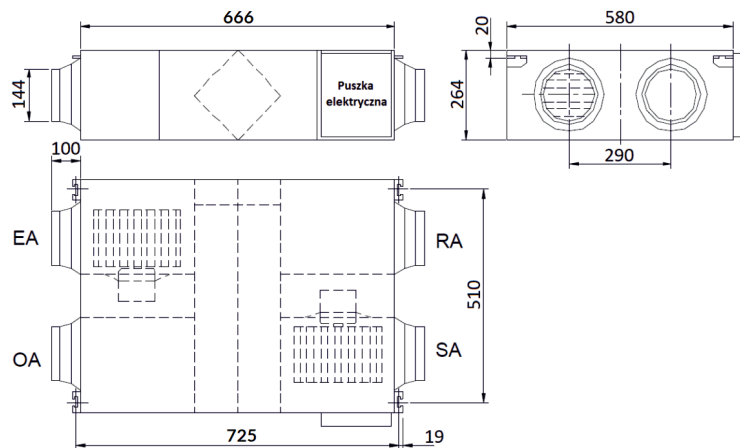

INSPIRO BASIC 300 - INSPIRO BASIC 1000

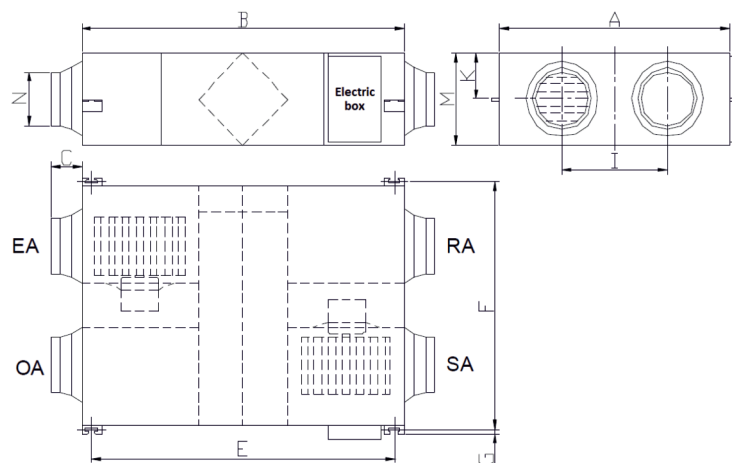

INSPIRO BASIC 1300

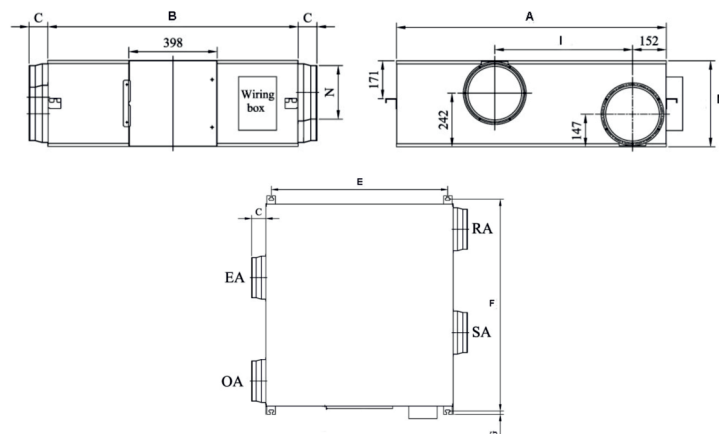

Model	A	B	C	E	F	G	I	K	M	N
INSPIRO BASIC 300	599	744	100	675	657	19	315	111	270	Ø 144
INSPIRO BASIC 400	804	744	100	675	862	19	480	111	270	Ø 144
INSPIRO BASIC 600	904	824	107	754	960	19	500	111	270	Ø 194
INSPIRO BASIC 800	884	1116	85	1045	940	19	428	170	388	Ø 242
INSPIRO BASIC 1000	1134	1116	85	1045	1190	19	678	-	388	Ø 242
INSPIRO BASIC 1300	1216	1129	85	1059	1273	19	621	-	388	Ø 242

2.3 TECHNICAL DATA

TECHNICAL DATA Product code	INSPIRO BASIC 200	INSPIRO BASIC 300	INSPIRO BASIC 400	INSPIRO BASIC 600	INSPIRO BASIC 800	INSPIRO BASIC 1000	INSPIRO BASIC 1300
	INSPIRO-BASIC 200-2022	INSPIRO-BASIC 300-2023	INSPIRO-BASIC 400-2024	INSPIRO-BASIC 600-2025	INSPIRO-BASIC 800-2026	INSPIRO-BASIC 1000-2028	INSPIRO-BASIC 1300-2027
Nominal airflow [m³/h]	200	300	400	600	800	1000	1300
Maximum enthalpy efficiency [%]	63	65	65	67	63	64	62
Maximum temperature efficiency [%]	75	73	74	76	74	76	76
Supply voltage [V] / Supply frequency [Hz]	220-240 / 50	220-240 / 50	220-240 / 50	220-240 / 50	220-240 / 50	220-240 / 50	220-240 / 50
Motor power [W]	105	117	150	200	355	440	710
Protection degree IP [-]	X2	X2	X2	X2	X2	X2	X2
Net weight [kg]	23	25	31	36	60	70	79
Noise [dB(A)]	31,5	34,5	37,5	39	41	42	43
Energy efficiency class [-]*	A	A	A	A	A	A	A

* według EU no. 1254/2014

2.4 WORKING CHARACTERISTICS

The below characteristics are made for $T_{OA} = 5^{\circ}\text{C}$, $\phi_{OA} = 58,5\%$, $T_{RA} = 21^{\circ}\text{C}$, $\phi_{RA} = 39,2\%$ and the airflows of supply and exhaust streams.

INSPIRO BASIC 200

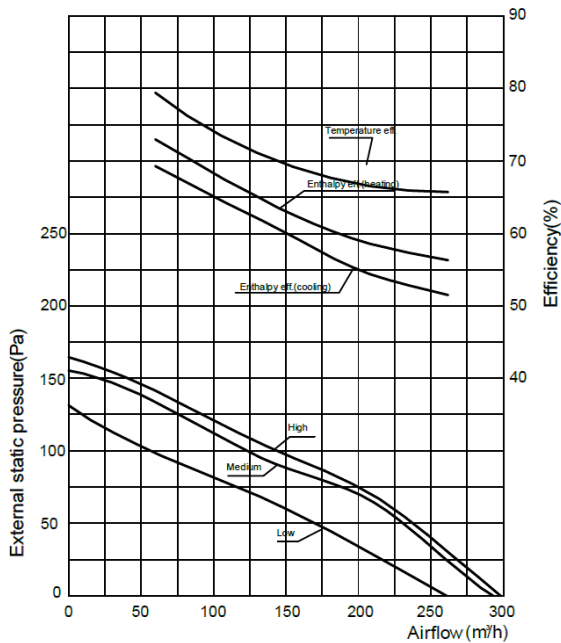

INSPIRO BASIC 300

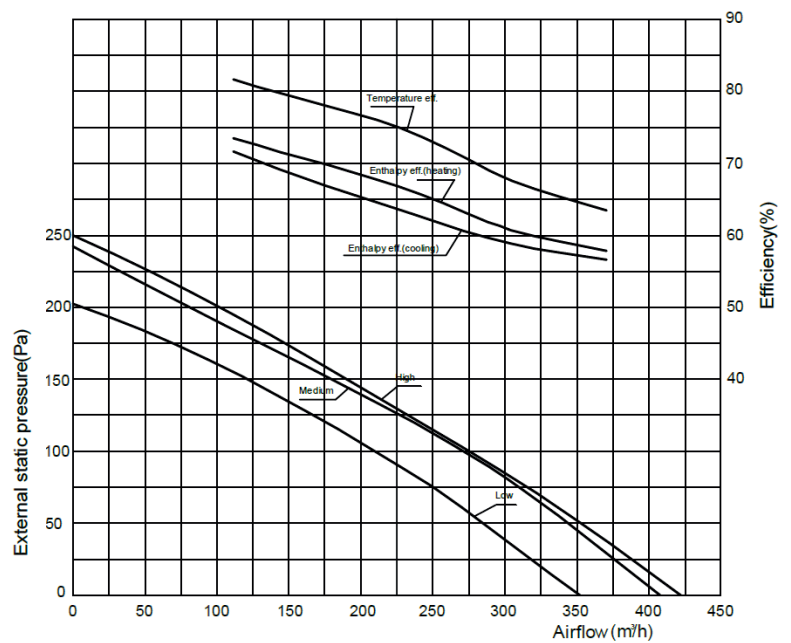

INSPIRO BASIC 400

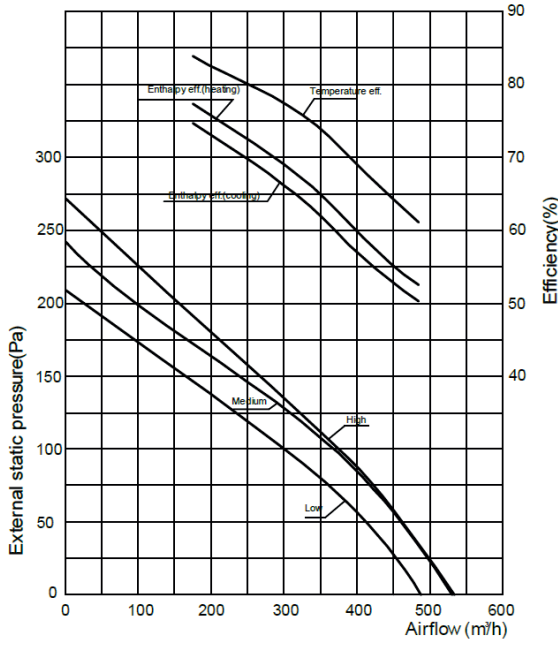

INSPIRO BASIC 600

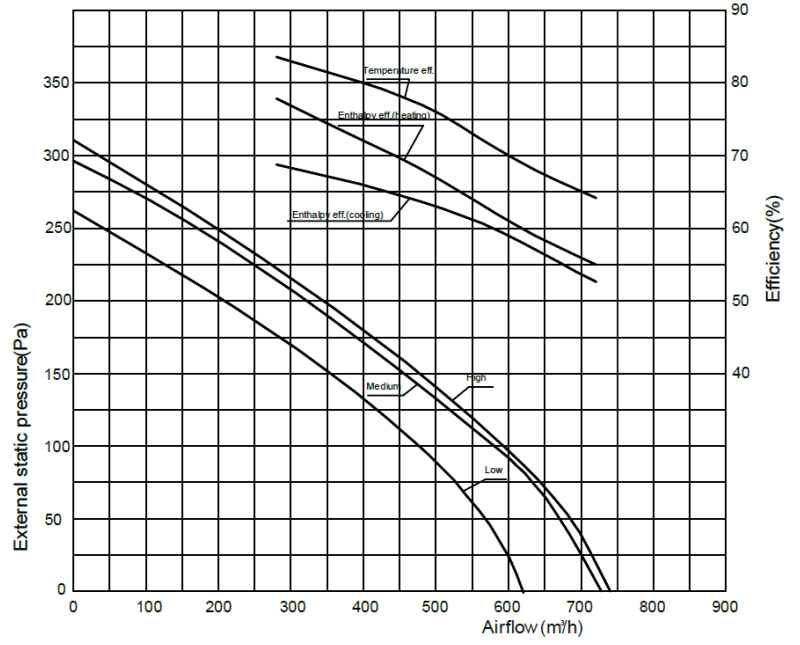

INSPIRO BASIC 800

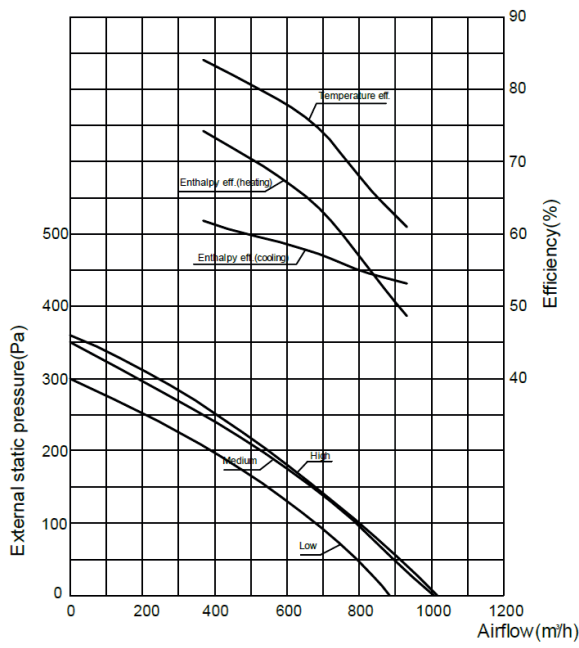

INSPIRO BASIC 1000

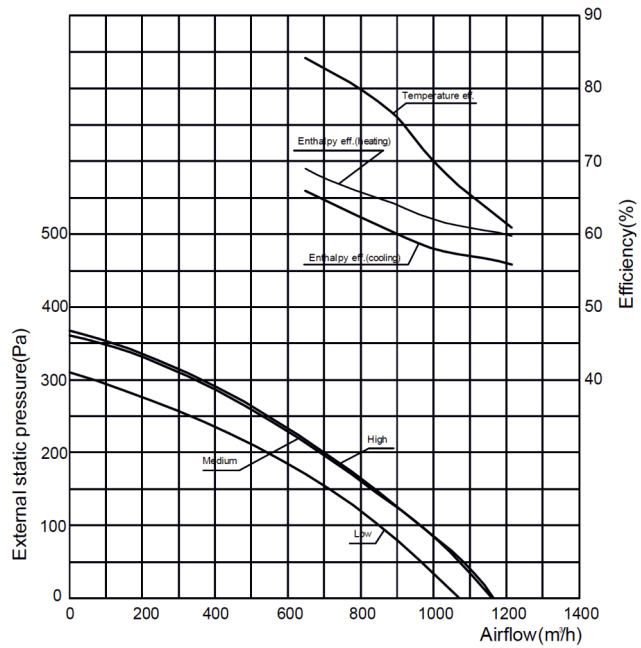

INSPIRO BASIC 1300

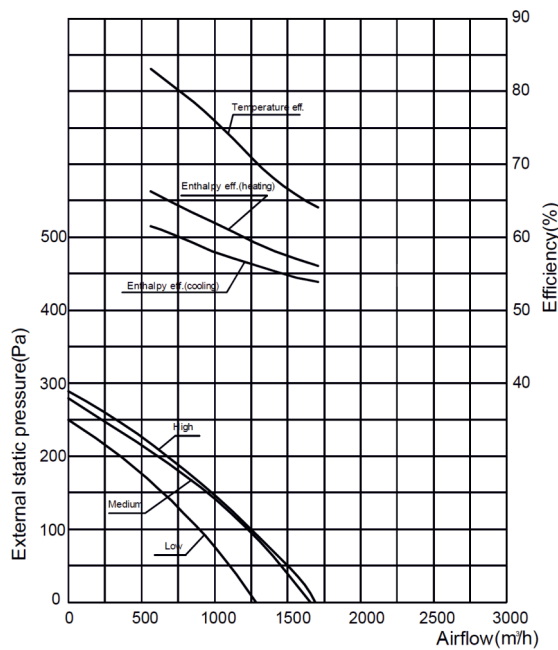

3. ASSEMBLY

3.1. GENERAL PRINCIPLES

- device is designed for hanging mounting
- mounting elements not included in the kit, you should buy them yourself and make sure they are suitable for this type of installation
- abbreviations OA/EA/SA/RA mean subsequently outdoor fresh air, exhaust air, supply air and return air
- it is not recommended to install the unit in a position where the inspection door would be pointed up or down
- protect the openings of the unit against the ingress of dust during installation
- the minimum gap in which the device will be installed is at least 320 mm (for INSPIRO BASIC 200 - INSPIRO BASIC 600) or 450 mm (for INSPIRO BASIC 800 - INSPIRO BASIC 1300)
- the device should be installed in a way that allows easy access to the inspection door and the electrical box - the recommended distance of inspection door from the nearest building partition depends on the model and should be equal or higher than the F dimension in section 2.2.
- exemplary installation with energy recovery unit is shown in the figure below

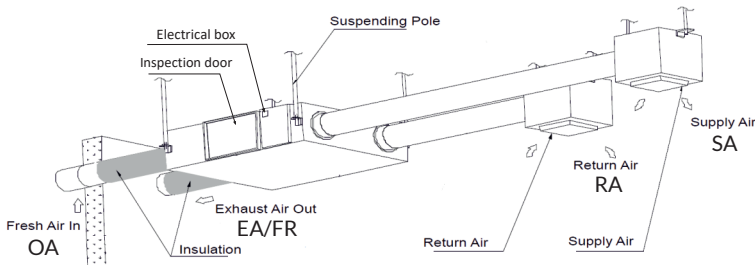

3.2 DUCTING

- connection between ducts and the openings of the device must be secured with tape or sealed in accordance with domestic or local norms
- outside ducts (i. e. fresh and exhaust air) should be thermally insulated and carried out with a drop of 1 - 2% toward the outside in order to prevent water entering into the unit
- the energy recovery unit and ducts cannot run close of flues (e.g. from boiler)
- it is not allowed to make ducts in the way shown below:



Excessive bending angle



Reduce the diameter of the junction part



Too many bending parts

- fire dampers must be installed in accordance with domestic or local fire regulations
- the device must not be exposed to an ambient temperature above 40°C
- outside ducts should be ended by intake and exhaust outlets, located in accordance with domestic or local norms
- before start up ensure there are no obstructions to or in the ducts
- operation of heater should be synchronous with the unit
- duct silencers can be used to minimize noise in the room

4. INSTALLATION INSTRUCTIONS

4.1. CONNECTION OF THE DEVICE TO THE ELECTRICAL SYSTEM

- all works concerning electrical installation should be made by the qualified personnel (who possess required authorizations to install electrical equipment), based on wiring schematic diagram (see point 7)
- the recommended cross sectional area of the supply wires is 1.5 mm²
- the maximal distance between the PCB and the control panel should not exceed 10m
- the electrical installation of the building shall have a residual current device
- it is recommended to check the electric installation and controls before the first start

5. PRECAUTIONS & WARNINGS

The precautions mentioned below must be strictly followed during operation of the device:

- all works concerning electrical installation (disassembly, repair etc.) should be made by the qualified staff, who possess the qualifications due to the domestic and local norms, regarding electrical installations
- do not use the unit for direct exhaustion of kitchen vapors - this may result in clogging of the exchanger and filters by fats and greases
- the unit should be protected against the influence of frost / water (i. e. appropriate insulation, preventing lowering the temperature in the room below 0°C, pre-heater, etc.)
- the unit should not be used for long-term supplying/exhausting air with relative humidity exceeding 80% and air temperature above 40°C
- the unit should not work without installed filters - this can lead to dirt and clogging of the enthalpy exchanger
- if there is a risk of frosting, preheater should be used
- before service or exchange of the device it is obligatory to cut off the current supply
- do not limit or cover the inlet and outlet of the device
- do not install, service the device with wet hands or barefoot
- the device should be kept out of reach of children and animals
- after operating time of the device, please utilize it concerning the local norms and regulations
- it is recommended to clean the device periodically:
- unit's casing clean from dirt (at least once per year)
- G3 filter blow with compressed air to remove dirt and dust (at least once per quarter)
- enthalpy heat exchanger clean from dirt (at least once per two year)
- for installation of the device in a place where is high dust concentration, the periodic cleaning of filter and exchanger should be performed much more often, not allowing the items to 'clog'
- failure to comply with cleaning obligations may have a negative effect on technical parameters of the device and lead to loss of warranty
- if the device is not used for a longer time and lead to loss of warranty disconnect the power supply

6. CONTROLS

6.1 CHARACTERISTIC

Energy recovery unit INSPIRO BASIC series has controller in the set, which optimise the unit operation. Communication with the controller is possible with control panel BASIC - detailed description of control panel operation can be found in point 6.3.



The main functions of the unit:

- **speed selection** - regulation of supply and exhaust fans airflows - 3 different speeds
- **weekly schedule** - it is possible to set a weekly work schedule of the unit
- **bypass** - the function allows to supply outside air directly (i. e. without energy recovery) if there is no heating / cooling demand
- **filter alarm** - after working over 1000 hours in total, the icon of filter alarm is displayed on the LCD screen - it reminds about necessity of filter cleaning
- **BMS communication** - the unit can be integrated with the BMS building control system

6.2 COMMISSIONING

After checking all wires and connections, switch on the device with button  and then:

1) Check the fans operation - in order to do that the following should be done:

- pressing button  set the manual mode  (hold the button pressed down for a few second after the first sound signal)

- using arrows  and  change the fans speed

2) Check the bypass operation - in order to do that the following should be done:

- press and hold button  during 2 seconds to switch between energy recovery and bypass mode

ATTENTION! For INSPIRO BASIC 800 fans switch off for several seconds when the bypass damper is moving.

6.3 CONTROL PANEL BASIC

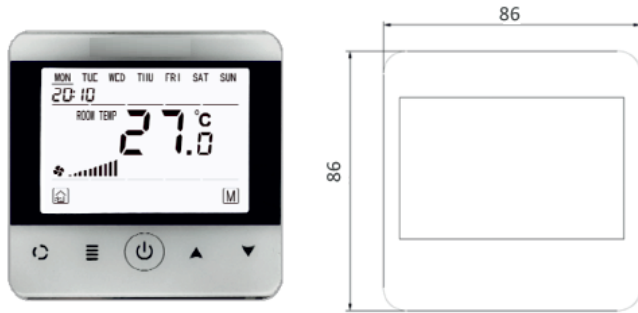

The control panel is supplied with 1 m cable, which can be extended if necessary (up to 10m).

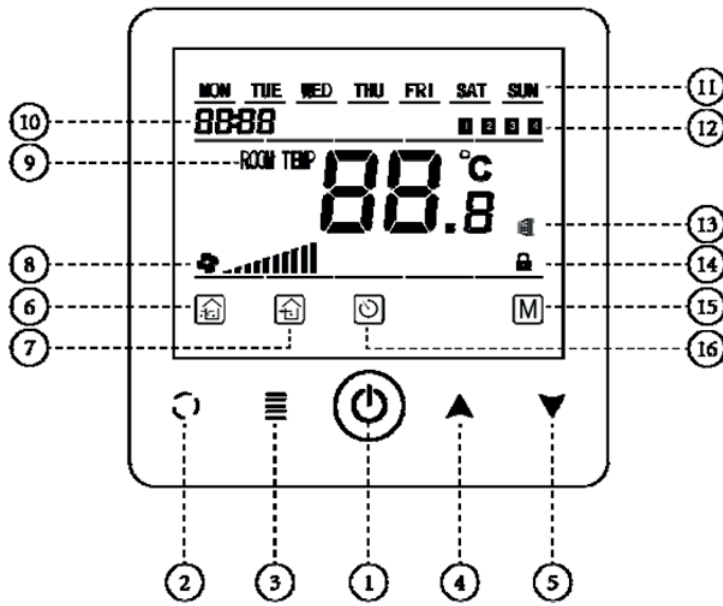

- 1 POWER ON/OFF
- 2 MODE
- 3 FUNCTION BUTTON
- 4 UP
- 5 DOWN
- 6 ENERGY RECOVERY MODE
- 7 BYPASS MODE
- 8 FAN SPEED
- 9 INDOOR TEMPERATURE
- 10 TIME DISPLAY
- 11 WEEK DISPLAY
- 12 TIME PERIOD
- 13 FILTER ALARM
- 14 DISPLAY LOCK
- 15 MANUAL MODE
- 16 AUTOMODE

- **POWER ON/OFF** - press this button to turn the device on/off
- **MODE** - press this button to set the mode (MANUAL or AUTO)
- **FUNCTION KEY** - set time and day of the week by this button
- **UP/DOWN** - use the arrows to navigate the menu and adjust fans speed

Controlling

Clock settings - press and hold for a few seconds FUNCTION button and when the day symbol starts to flash, select a day with UP and DOWN. In order to confirm and move in time setting, press again FUNCTION button and set hour in the analogous manner. Press again FUNCTION button and set minutes. In order to save and exit the time settings, press MODE.

Operation mode settings - to change between manual and auto mode use MODE button (hold the button pressed down for a few second after the first sound signal). The current mode is indicated by the icon on the display (icon 15 or 16).

In the manual mode, use the buttons UP/DOWN to change fans speed.

In auto mode set the program for particular periods of days. In this case, when the auto mode is selected (16), press FUNCTION button, select a day of the week and - with UP, DOWN and FUNCTION buttons - set time and fans speed of first period (1). In this way, it is possible to set schedule for four periods of each day. To end the setting of schedule, press MODE. If without operation for 10 seconds, the system will also save settings automatically.

Default settings of auto mode are in table below.

Week	Period	Fans stage	Period	Fans stage	Period	Fans stage	Period	Fans stage
Monday	1	III	2	II	1	I	1	Fans off
	8:00		8:00		8:00		8:00	
Tuesday	1	III	2	II	1	I	1	Fans off
	8:00		8:00		8:00		8:00	
Wednesday	1	III	2	II	1	I	1	Fans off
	8:00		8:00		8:00		8:00	
Thursday	1	III	2	II	1	I	1	Fans off
	8:00		8:00		8:00		8:00	
Friday	1	III	2	II	1	I	1	Fans off
	8:00		8:00		8:00		8:00	
Saturday	1	III	2	II	1	I	1	Fans off
	8:00		8:00		8:00		8:00	
Sunday	1	III	2	II	1	I	1	Fans off
	8:00		8:00		8:00		8:00	

Display lock - press and hold in the same time both MODE and UP to lock the display. It is indicated by padlock icon on the display. To unlock display, press and hold MODE and UP again.

Filter alarm - when unit works over 1000 hours in total, control panel shows the icon (13) reminding about necessity of filters cleaning. After cleaning press and hold for 5 seconds the button DOWN to delete the icon.

Bypass - to open the bypass damper, press and hold for 2 seconds the arrow UP. Press and hold the button again to close the damper and choose energy recovery mode. Actually operation mode is indicated by appropriate icon on the display (icon 6 or 7).

Silence operation - when the control panel is on, press and hold at the same time both POWER ON/OFF and MODE in order to turn the sound off. Press and hold the same buttons again to return the sounds of panel.

Restore default settings - when the control panel is on, press and hold at the same time both FUNCTION and DOWN buttons. The default values are following:

Function	Default	Function	Default
Power ON/OFF	OFF	Display lock	Closed
Times	Real time	Auto mode period I	Start time: 5:00 Fans speed: I stage
Operation mode	Manual	Auto mode period II	Start time: 7:00 Fans speed: I stage
Fans speed (manual mode)	I stage	Auto mode period III	Start time: 17:00 Fans speed: I stage
Bypass function	Closed	Auto mode period IV	Start time: 22:00 Fans speed: I stage

Temperature calibration - if the device is off, press and hold for 5 seconds FUNCTION button. Then with UP and DOWN buttons set the calibration of inside temperature within the range - 9 to 9°C. Press MODE to exit and save the value of calibration. If without operation for 10 seconds, the system will also save settings automatically.

7. CONNECTIONS SCHEMES

INSPIRO BASIC 200 - INSPIRO BASIC 600

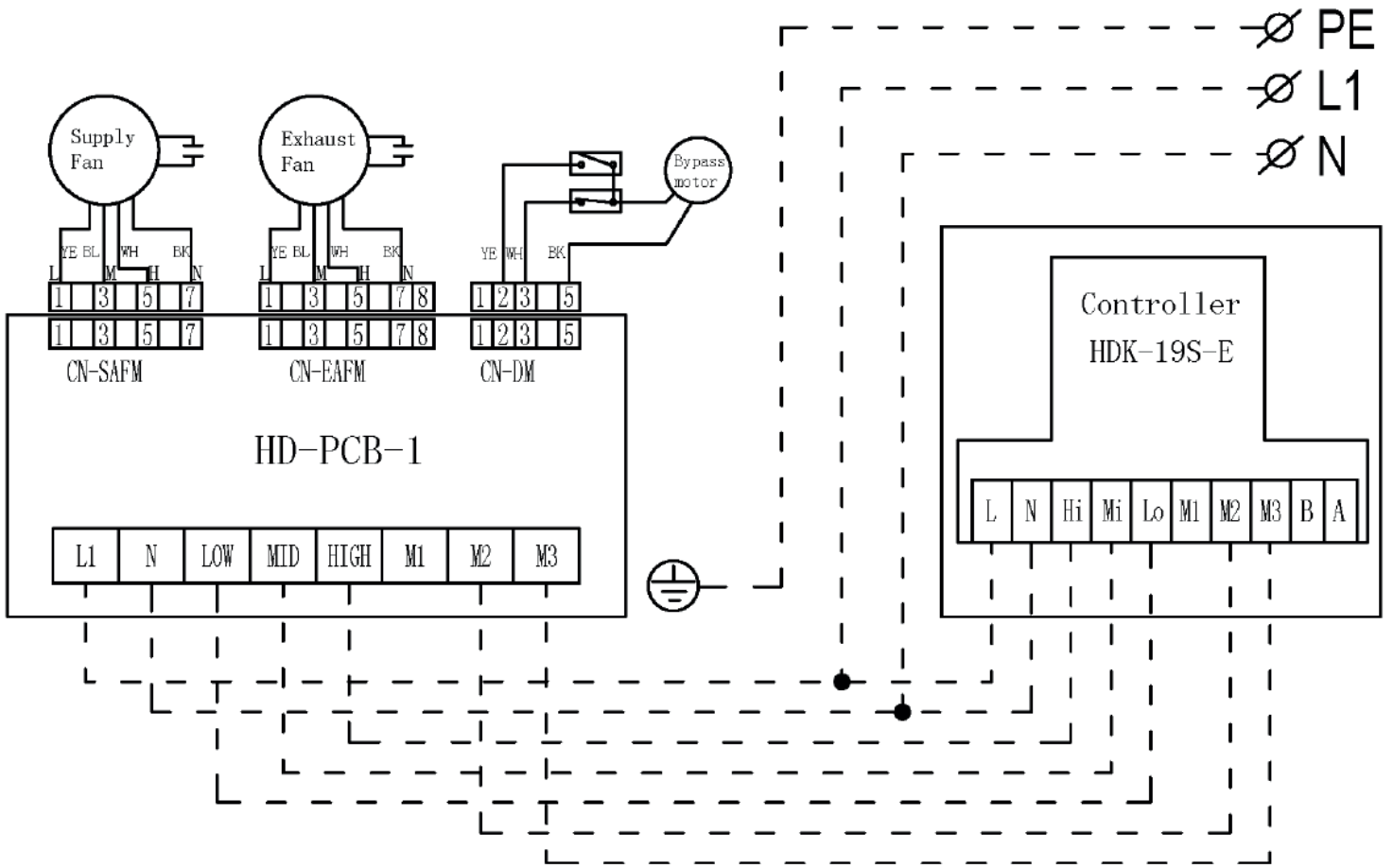

INSPIRO BASIC 800 - INSPIRO BASIC 1300

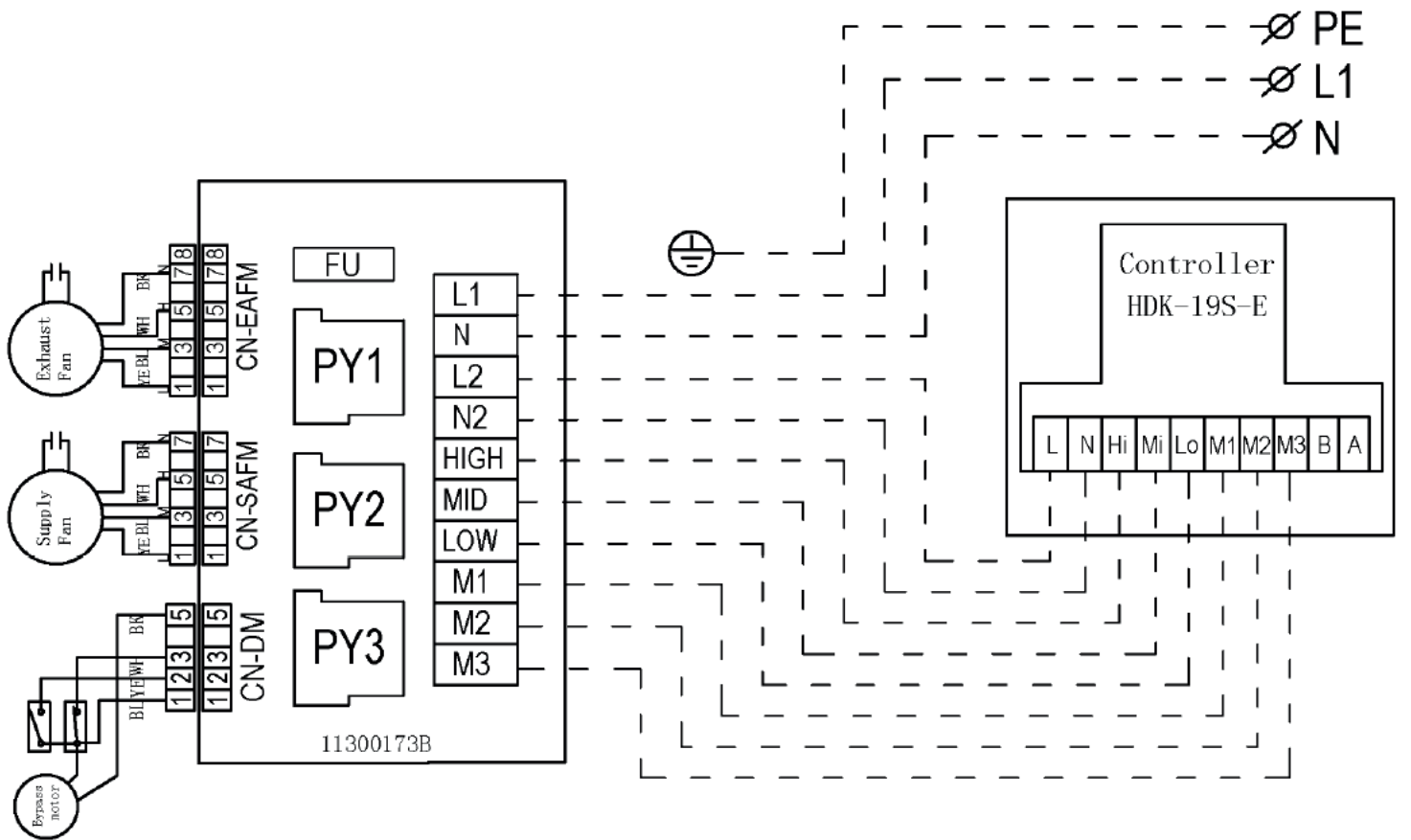

8. WARRANTY TERMS

I. The company Reventon Group Sp. z o. o. [Ltd.], hereinafter referred to as the guarantor, provides to the owner 24-month warranty protection period for the following devices:

- energy recovery unit INSPIRO BASIC 200
- energy recovery unit INSPIRO BASIC 300
- energy recovery unit INSPIRO BASIC 400
- energy recovery unit INSPIRO BASIC 600
- energy recovery unit INSPIRO BASIC 800
- energy recovery unit INSPIRO BASIC 1000
- energy recovery unit INSPIRO BASIC 1300

II. The warranty protection is valid from the purchasing date by end user (i.e. the issue date of invoice) but not longer than 30 months from leaving the warehouse of Reventon Group Sp. z o. o. [Ltd.].

III. The warranty claim should be reported via the complaint form on the website (<https://reventongroup.eu/en/complaints>). The scan or the photo of the fulfilled Warranty Card and the purchase invoice must be attached to the form. The Warranty Card is not required in case of accessories.

IV. The guarantor is committed to consider the claim within 14 working days since the date of reporting (i. e. the day of receipt of the correctly fulfilled warranty form).

V. In exceptional cases, the guarantor reserves the right to extend the time for consideration of the request, especially if the defect is not permanent one and its determination requires a deeper analysis. The extension must be notified by the guarantor before the end of the 14th working day.

VI. Under the warranty, the guarantor provides a repairment, replacement (the device or its component) or refund for the defective item within a specified time.

VII. In the case of replacement of a device component, the warranty protection of the whole unit is not prolonged.

VIII. The guarantor does not cover the costs of disassembly and eventual reassembly of the complaint device.

IX. The guarantor may decide to bring the defective device or its component to the service of Reventon Group Sp. z o. o. [Ltd.]. In such case the transport of the item is organised and paid by the guarantor. The responsibility of the device's owner is to prepare the item for the shipment - the device must be packed in a way which protects it against transport damages and the dimensions and weight of the package must not exceed 660 x 650 x 400 mm and 30 kg respectively. In the case of elements which cannot be packed in this way, the method of shipment must be agreed and approved by Reventon Group Sp. z o. o. [Ltd.]. In the case of sending a non-standard package without agreement of the service of Reventon Group Sp. z o. o. [Ltd.], the guarantor reserves the right to charge the owner of device with all additional transport costs.

X. In the case of arrival of the authorized service of the guarantor or an installer to fix the complaint item, the customer must ensure them seamless access to the device and all required media like electricity, water, lighting etc. free of charge.

XI. The warranty protection does not cover the parts of the device subject to the normal usage and the following cases:

a) mechanical damage of the product

b) defects and damages through:

- improper storage or transport
- improper or non-compliant use and maintenance (i. e. inconsistent with the manual)
- using the device in the improper conditions (too high humidity, too high or too low temperature, impact of the surrounding, sun etc.)
- unauthorized (i. e. by the user or other unauthorized persons) repairs, modifications or construction changes
- connecting equipment inconsistent with the technical documentation
- connecting additional equipment, which is not recommended by the guarantor
- improper power supply
- random events (like fire, flood, storm etc.)

c) elements which wear and tear such as discolour of the housing

If there is any of the above, the claimant will be charged for transport and/or repairs.

XII. During collection of the device, the item must be checked exactly by the receiver to exclude transport damages. If any of them is observed, the damage report in presence of the product deliverer have to be filled - such report is the basement for the warranty claim. The damage report must be provided by the product deliverer.

XIII. The guarantor does not take the responsibility for potential losses and damages related to the downtime of the device during its failure and the complaint considering time.

XIV. Any changes in the Warranty Terms, improper use of the product as well as traces of self repairing (beyond the guarantor service) or alterations cause, the warranty become invalid.

XV. These Warranty Terms do not exclude or limit any rights arising from the pledge.

XVI. Not following to any of the warranty regulations makes the protection invalid.

XVII. All correspondence should be sent to the following address: Reventon Group Sp. z o. o. [Ltd.], 556 Wyzwolenia Street, 43 340 Kozy, Poland or email address: serwis@reventongroup.eu.

Warranty Card

1 - Model and serial number* or product code	2 - Address and place of assembly
3 - Date of connection to: Heating/cooling installation (if applicable)	4 - Stamp and signature of installer:
Ventilation installation (if applicable)	
Electrical installation (if applicable)	

* serial number is required only for water heaters HC-3S, HC-EC and FARMER HCF series and recovery units INSPIRO, INSPIRO BASIC and VERTIC series



reventon

Reventon Group Sp. z o.o. [Ltd.], 556 Wyzwolenia Street, 43-340 Kozy, Poland, www.reventongroup.eu